



ISSN: 0975-833X

Available online at <http://www.journalcra.com>

INTERNATIONAL JOURNAL
OF CURRENT RESEARCH

International Journal of Current Research
Vol. 13, Issue, 09, pp.18733-18739, September, 2021

DOI: <https://doi.org/10.24941/ijcr.42053.09.2021>

RESEARCH ARTICLE

EXPERIMENTAL INVESTIGATION ON HOLLOWED CLAY BRICK

^{1,*}Dr. Inbanila T. and ²Dr. Rajasekaran, A.

¹Department of Civil Engineering, University College of Engineering, Panruti

²Professor, Department of Civil & Structural Engineering, Annamalai University

ARTICLE INFO

Article History:

Received 25th June, 2021

Received in revised form

20th July, 2021

Accepted 19th August, 2021

Published online 30th September, 2021

Key Words:

Ash, Brick, Clay, Rice Husk, Saw .

*Corresponding author:

Dr. Inbanila T.

ABSTRACT

This paper presents the experimental investigation on hollowed clay brick to enumerate its sound insulation. A total of 90 test specimens were cast and tested with variations for each of 6 specimens. To create the sound insulation inside the brick by using chart paper boxes placed in the core area of brick with combustible material such as saw, rice husk and cow dung. After the process of burning the combustible materials fully burned and turned into ash. The findings of the study concluded that the sound insulation of single hollowed brick is 2-3% greater than that of ordinary brick. In double hollowed 1.5% and triple hollowed bricks was 1.9% higher than the ordinary brick.

Copyright © 2021. Inbanila and Rajasekaran. This is an open access article distributed under the Creative Commons Attribution License, which permits unrestricted use, distribution, and reproduction in any medium, provided the original work is properly cited.

Citation: Dr. Inbanila T. and Dr. Rajasekaran, A. "Experimental investigation on hollowed clay brick", 2021. *International Journal of Current Research*, 13, (09), 18733-18739.

INTRODUCTION

Bricks are more commonly used in the construction of buildings than any other material except wood. Brick and terracotta architecture is dominant within its field and a great industry has developed and invested in the manufacture of many different types of bricks of all shapes and colours. Bricks can be made from a variety of materials, the most common being clay but also calcium silicate and concrete. The present day constructions have RCC (Reinforced concrete cement) columns and mainly bricks are used as partition walls. They are no longer being used as load bearing walls in majority of the buildings. A shift towards REBs would help saving fuel and reducing pollution in brick production process. There is also significant reduction in the consumption of top (agriculture) soil which is the main raw material in brick making. Increased use of REBs in building construction would also help in reducing the energy consumption of building due to their better insulation properties. The demand for brick has been increasing with the ever increasing activities in the construction sector. In the last ten years the demand for bricks has increased specially in the major towns and cities. As a result no of new brick plants have been set up around the cities which are catering to the local demand.

Sound or noise transmission may be an everyday occurrence and, for some occupants, a series of random and uncontrollable events. This can lead to frustration, anger and stress for occupants. To overcome this situation this innovative method would improve the sound insulation from the neighboring dwelling.

LITERATURE REVIEW

Zukowski and Haese (2010) investigated the effective thermal properties of a modern vertically perforated masonry unit filled with perlite insulation. Based on measurements and numerical calculations, the thermal performance of the new hollow brick was determined. The authors suggest to use the following parameters for this building material: equivalent heat capacity equal to 855.1 J/kg K, equivalent heat conductivity equal to 0.09 W/mK and equivalent density equal to 653.15 kg/m³. The dependence of the equivalent thermal resistance of the whole wall made of this brick and mortar, is shown for different mortar joint thicknesses. All results, presented in this paper, can be used in energy balance calculations for buildings made of masonry unit. Venkatarama Reddy and Jagadish (2003) stated that considerable amount of energy is spent in the manufacturing processes and transportation of various building materials.

Conservation of energy becomes important in the context of limiting of green house gases emission into the atmosphere and reducing costs of materials. The paper is focused around some issues pertaining to embodied energy in buildings particularly in the Indian context. Energy consumption in the production of basic building materials (such as cement, steel, etc.) and different types of materials used for construction has been discussed. Energy spent in transportation of various building materials is presented. A comparison of energy in different types of masonry has been made. Energy in different types of alternative roofing systems has been discussed and compared with the energy of conventional reinforced concrete (RC) slab roof. Total embodied energy of a multi-storeyed building, a load bearing brickwork building and a soil-cement block building using alternative building materials has been compared. It has been shown that total embodied energy of load bearing masonry buildings can be reduced by 50% when energy efficient/alternative building materials are used.

AmmarBouchair (2008) proposed a theoretical model to study the steady state thermal behavior of fired clay hollow bricks for enhanced external wall thermal insulation. The study aims at the development of new materials and structural components with good thermal material properties, with respect to energy saving and ecological design. Thermal insulation capacity of two external walls of different thicknesses, constructed of locally produced bricks, is studied. The basic brick units used for the investigation are small-size bricks with eight equal cavities or recesses and big-size bricks with twelve equal recesses. Computer modeling and calculations performed, for steady state conditions, show that the increase in hollow brick cavity height contributes to the improvement of the overall thermal resistance of the order of 18–20%. The improvement could significantly increase to the range of 88.64% and 93.33%, if the bricks used are injected with the insulating material.

Vaclav Koci *et al.*, reported that the thickness of the thermal insulation layer can be reduced several times if the up-to-date hollow bricks with lightened brick body and sophisticated systems of internal cavities are used, instead of traditional bricks or the old-fashioned hollow bricks with only several large cavities. The designed brick-built passive house is thus almost equalized with the timber-based houses from a point of view of building envelope thickness. In addition, it preserves some very important advantages characteristic for common brick structures, such as the fast water vapor transport through the wall, good thermal accumulation properties and fire resistance, or a low risk of biological degradation.

Jan koci *et al.*, (2015) stated that the hollow clay brick blocks with complex systems of internal cavities present a prospective alternative to the traditional solid bricks on the building ceramics market. Determination of their thermal properties, which are essential for any energy-related calculations, is though not an easy task. Contrary to the solid bricks, the application of sophisticated methods is a necessity. In this paper, a fast computational approach for the determination of equivalent thermal conductivity of hollow brick blocks with the cavities filled by air is presented, which can be used as an integral part of energy-related calculations. The thermal conductivity of the brick body is the main input parameter of the model, the convection and radiation in the cavities are taken into account in a simplified form. The error range of the designed method is identified using a thorough uncertainty

analysis. A direct comparison of the calculated equivalent thermal conductivity with the results obtained by two different experimental techniques for the same hollow brick block shows a satisfactory agreement, making the designed computational approach a viable alternative to the currently used methods

ADVANTAGES OF SELF HOLLOWED CLAY BRICK:

A vacuum is made in the inside area of this brick would help to reduce the intensity of sound. This is only used in ordinary residential building, auditorium, library and theatre (not for high rise building). This brick is economical because the use of locally available material. Many new inventions are out of necessity. The traditional construction materials like burnt solid clay bricks became in short supply and hence in high demand and high cost. Moreover they are manufactured at certain places and transported from there. All this affected cost and even in the quality to the brick also. Hollow bricks are a good construction material. Nowadays, it is used at various construction buildings and compound wall. Many people used this hollow bricks because it reduces heat and make the building in cool. Provide thermal and sound insulation: The air in hollow of the brick, does not allow outside heat or cold in the house. So it keeps house cool in summer and warm in winter.

MATERIALS USED FOR INVESTIGATION

Materials used in brick making are

-) Clay
-) Combustible material such as saw, rice husk and cow dung.
-) Plaster of Paris
-) Chart paper used to keep the combustible material



Fig. 1. Rice husk



Fig. 2 Clay



Fig. 3. Saw



Fig. 4. Cow Dung

Properties of Clay: Clays are hydrous aluminium silicates, usually containing minor amounts of impurities such as potassium, sodium, calcium, magnesium, or iron. Properties of clay minerals include plasticity, shrinkage under firing and air drying, fineness of grain, colour after firing, hardness, cohesion, and capacity of the surface to take decoration. On the basis of such qualities, clays are variously divided into classes or groups. Individual clay particles are always smaller than 0.004 mm. Clays often form colloidal suspensions when immersed in water, but the clay particles flocculate (clump) and settle quickly in saline water.

Properties of Rice Husk: RHA, produced after burning of Rice husks (RH) has high reactivity and pozzolanic property. Chemical compositions of RHA are affected due to burning process and temperature. Silica content in the ash increases with higher the burning temperature. As per study by Houston, D. F. (1972) RHA produced by burning rice husk between 600 and 700°C temperatures for 2 hours, contains 90-95% SiO₂, 1-3% K₂O and < 5% unburnt carbon. Under controlled burning condition in industrial furnace, conducted by Mehta, P. K. (1992), RHA contains silica in amorphous and highly cellular form, with 50-1000 m²/g surface area. So use of RHA improves workability and stability, reduces heat evolution, thermal cracking and plastic shrinkage.

Properties of Cow Dung: The cow dung ash is obtained from cow excreta which is dried to sunlight and subjected to burning as a result ash is obtained in black color. It possess physical properties such as its bulky, large ash content, low volatile content after burning, low carbon content and low burning ratio is low. Also it possess chemical properties such as nitrogen rich, potassium, phosphorous and calcium. (Smith and Wheeler, 1979). Cow dung has a

relatively high carbon to the nitrogen ratio. Chemical composition of the cow dung revealed that while there was no difference in the organic matter (OM), nitrogen (N) and manganese (Mn). Contents of calcium (Ca), phosphorus (P), zinc (Zn) and copper (Cu) were higher by 10.8, 8.0, 84.1 and 21.7 percent in the dung (Garg and Mudgal, 2007).

Chemical composition of Saw Dust Ash: The Chemical composition of Saw Dust Ash (SDA) is shown in Table 1. The average percentage composition of SiO₂ + Al₂O₃ + Fe₂O₃ is 74.89%. This satisfies the minimum percentage requirement for pozzolanas which is 70% according to ASTM C 618 (1994). As reported by Jerath and Hanson (2007), SDA falls under the category of Class F fly ash since the sum of (SiO₂ + Al₂O₃ + Fe₂O₃) is greater than 70%.

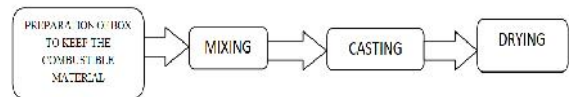

METHODOLOGY

Preparation of Box to Keep the Combustible Material

-) The combustible materials are filled inside the box of various dimensions (such as 7cmx 3cmx 3cm, 8cmx 3cmx 3cm, 9cmx 3cmx 3cm etc)
-) There are three types of bricks are made.
-) In first type only one box placed inside (in the middle) the bricks.
-) In the second type of brick is made by using two boxes of same dimension placed inside the bricks.
-) Similarly the third type of bricks having three boxes in the core area of brick.



Fig. 4. Boxes made by chart paper

Mixing

-) First of all the proportions are weighed in proper ratio.
-) To clean the surface without any dirt, for mixing of all materials in proper proportions.
-) Then the proper mix has done with the using of trowel.
-) 10- 15% of water is added to mixed proportion.
-) In order to increase the strength of the brick 350gms of pop is added for 25kg of clay mix.

Casting: The brick is moulded in the following way i.e. hand moulding.



Fig. 5. Mixing

The moulding of bricks with hand, using moulds which are prepared at designed shape, is to be done on ground is known as ground moulded bricks. The moulding process is done in three stages as given below.

Stage 1: This is an initial stage in which bottom layer is laid by clay for 3cm height.



Fig. 6. Triple hollow brick

Stage 2: In this stage second layer was laid by clay for 3cm height then the boxes are placed in that layer.

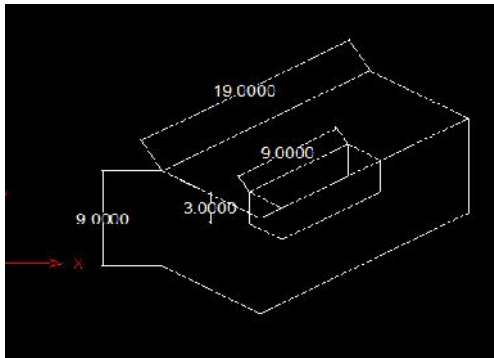

Fig. 7. Single hollow brick

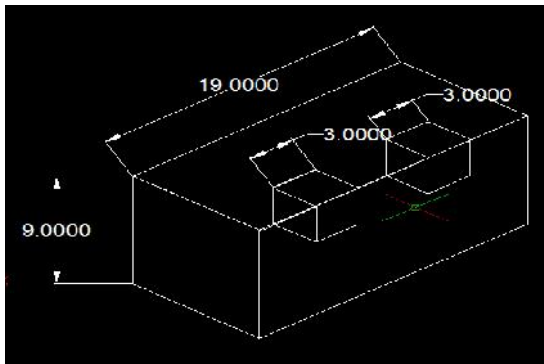

Fig. 8 double hollow brick

Stage 3: This is the final stage of moulding process. In this stage the visible parts of the boxes are covered by the third layer of clay having 3cm height and finish the rough surface of the bricks smoothly.



Fig. 9. Moulding



Fig. 10. Finishing

Drying

The main objectives of drying the moulded bricks are as follows

-) If damp or green bricks are directly taken for next operation of to remove maximum possible moisture from the brick by the atmosphere temperature for 3 to 4 days.
-) The bricks are taken for burning process after drying.



Fig. 11. Drying

Table 1. Test Specimen Designation

Specimen Designation	Type of brick	Size of hollow	Material inside the hollow	No of Samples
SH1R	SH	7cmx3cmx3cm	RHA	6
SH2R	SH	8cmx3cmx3cm	RHA	6
SH3R	SH	9cmx3cmx3cm	RHA	6
SH1C	SH	7cmx3cmx3cm	CDA	6
SH2C	SH	8cmx3cmx3cm	CDA	6
SH3C	SH	9cmx3cmx3cm	CDA	6
SH1S	SH	7cmx3cmx3cm	SDA	6
SH2S	SH	8cmx3cmx3cm	SDA	6
SH3S	SH	9cmx3cmx3cm	SDA	6
DHR	DH	3cmx3cmx3cm	RHA	6
DHC	DH	3cmx3cmx3cm	CDA	6
DHS	DH	3cmx3cmx3cm	SDA	6
THR	TH	2cmx3cmx3cm	RHA	6
THC	TH	2cmx3cmx3cm	CDA	6
THS	TH	2cmx3cmx3cm	SDA	6
Total				90

Note: SH-single hollowed brick, DH-double hollowed brick, TH-triple hollowed brick, RHA-Rice husk ash, CDA-Cow dung ash, SDA-Saw dust ash



Fig. 12. Sound level meter



Fig. 13 Manual set up

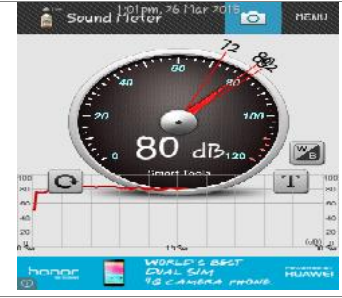

Fig. 14. Readings from mobile application



Fig. 15. Compression testing machine



Fig. 16. Water Absorption

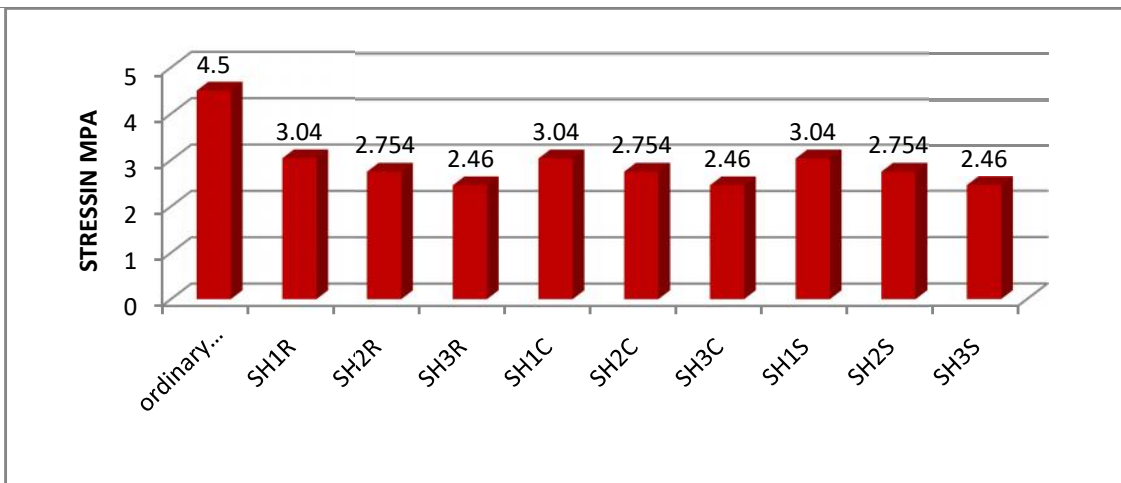

Fig. 17 Compressive strength test (single hollowed brick)

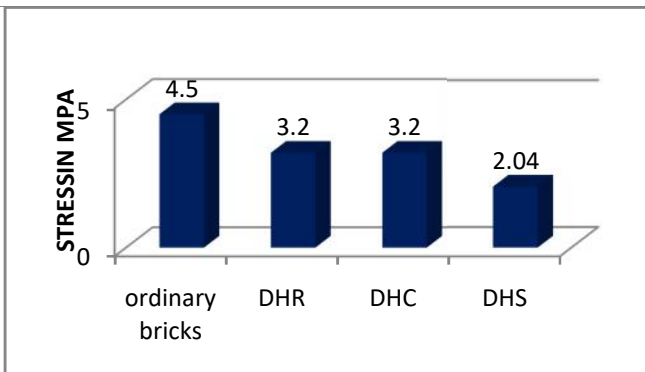

Fig. 18 compressive strength test (Double hollowed brick)

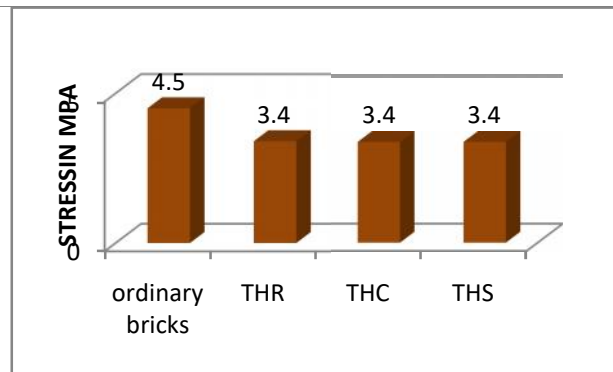

Fig. 19 compressive strength test (triple hollowed brick)

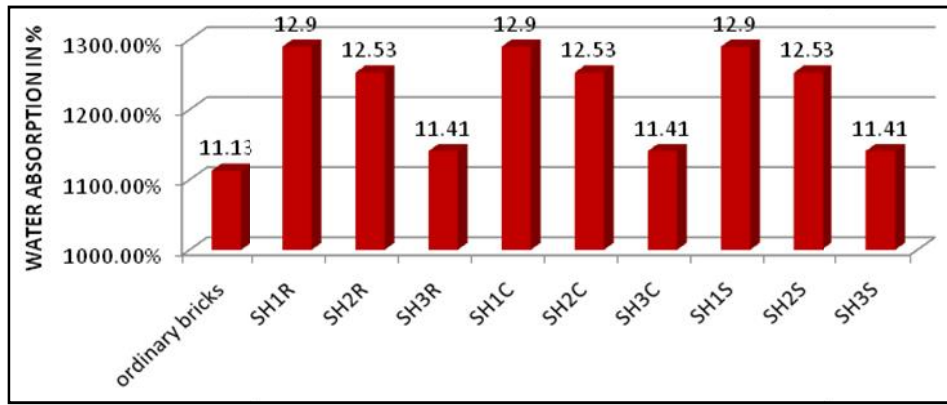

Fig.20 Water absorption test (single hollowed brick)

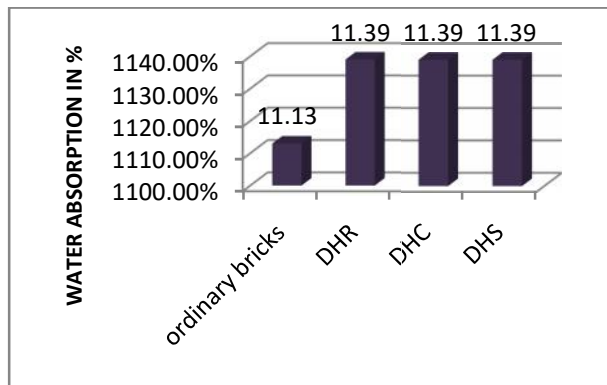

Fig. 21 Water absorption test (double hollowed brick)

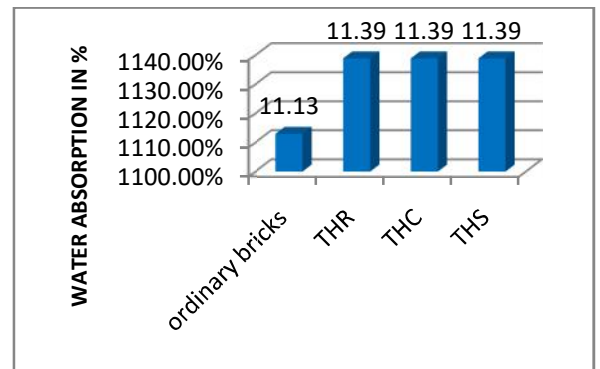

Fig. 22 Water absorption test (triple hollowed brick)

Test Results of Sound Insulation Test

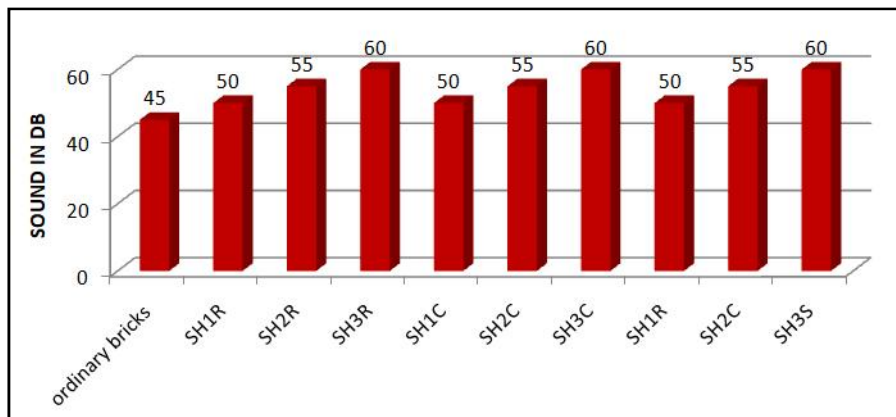

Fig. 23 Sound insulation test (single hollowed brick)

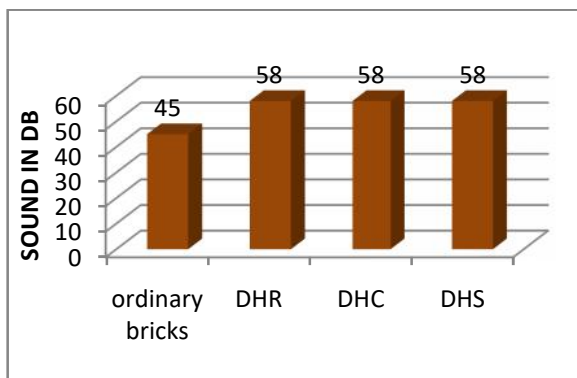

Fig. 24 Sound insulation test (double hollowed brick)

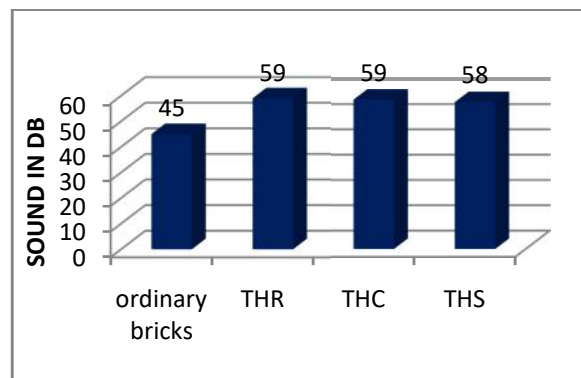

Fig. 25 Sound insulation test (triple hollowed brick)

Rice husk ash, CDA-Cow dung ash, SDA-Saw dust ash: All the test specimens subjected to the following laboratory tests such as Compressive strength, Water Absorption and Sound insulation, to find their suitability as per Indian Standards. The equipment's used in this study are presented in Figs. 12 to 16.

RESULTS AND DISCUSSION

In this study the compressive strength and water absorption characteristics, sound insulation capacity and unit weight comparison for burnt hollow clay bricks, Ordinary Clay Bricks were investigated. The tests were carried out on hand molded bricks. It was observed that all the bricks satisfy the requirement of India Code in respect of compressive strength as well as water absorption characteristics.

CONCLUSION

It has been observed that the water absorption capacity of single hollowed brick is 0.22-1.23% higher than the ordinary clay brick. In double and triple hollowed brick the water absorption capacity 0.2% higher than the ordinary brick. But the compressive strength of these bricks is lower than the Ordinary brick. In single hollowed brick compressive strength 10-18% lower than the ordinary brick. In double hollowed brick 9% and triple hollowed bricks were 7% lower than ordinary brick. At the same time the sound insulation of single hollowed brick 2 -3% greater than that of ordinary brick. In double hollowed 1.5% and triple hollowed bricks were 1.9% higher than the ordinary brick.

REFERENCES

- Abad E, Caixach, J Rivera J, Gustine's L, Massage G, and Puigo, 2004. Temporal trends of PCDDS/PCDF in ambient air in Catalonia (Spain), science of the total environment.
- Ammar Bouchair "Steady state theoretical model of fired clay hollow bricks for enhanced external wall thermal insulation", Building and environment, volume 43, October 2008, pages 1603-1618.
- Aripnammal, S. and Natarajan, S. 1994. 'Transport phenomena of SmSel -X Asx' pramama-journal of physics Vol.42, No.1,pp.421-425.
- Barnard, R.W. and Kellogg, C. 1980. 'Applications of convolution operators to problems in Univalent Function Theory', Michigan math. j., vol.27, pp.81-94.
- IS 3952-1988 - Specification for burnt clay hollow bricks for walls and partitions
- Jan koci, jiri Madera, Robert cerny. "A fast computational approach for the determination of thermal properties of hollow bricks in energy-related calculations". Energy, volume 83, April 2015, pages 749-755.
- Shin, K.G. and McKay, N.D. 1984. 'Open Loop Minimum Time Control of Mechanical Manipulations and its Applications', proc. Amer. Conf. San Diego, CA, pp.1231-1236.
- Zukowski, M., G. Haese "Experimental and numerical investigation of a hollow brick filled with perlite insulation". Energy and buildings volume 42, September 2010, pages 1402-1408.
