



## RESEARCH ARTICLE

### DESIGN OF A 3KVA SOLAR ENERGY PLANT FOR THE CAMPUS COMMUNITY OF MICHEAL OKPARA UNIVERSITY OF AGRICULTURE, UMUDIKE

**Asiegbu, A.D.**

Department of Physics, Michael Okpara University of Agriculture, Umudike

#### ARTICLE INFO

##### *Article History:*

Received 15<sup>th</sup> October, 2010

Received in revised form

18<sup>th</sup> October, 2010

Accepted 14<sup>th</sup> November, 2010

Published online 5<sup>th</sup> December, 2010

#### ABSTRACT

In this work a 3kVA Photovoltaic system capable of sustaining 5 campus offices has been designed, with an array of 14 panels each of 150W rating and a battery bank of 10, 200AH/12V batteries, the design is capable of sustaining power from storage to a maximum of 2 days without sunlight.

##### **Key words:**

PV system,

Power,

Panel,

Solar energy,

Solar array.

© Copy Right, IJCR, 2010 Academic Journals. All rights reserved.

## INTRODUCTION

Harnessing of renewable energy resources is now a global concern. Increased awareness is now being created in developing countries such as Nigeria where the environment is potentially endowed with renewable energy resources. The global economy is heavily infested with electronic gadgets used at homes and offices, also ICT which is now an integral part of modern civilization, all place much demand on daily power consumption. Often times the national grid runs deficit of the power demand in urban centres while there is hardly any hope of power supply to the suburbs. A lot of efforts are being made globally both to harness and to improve on existing technologies for harnessing

solar energy for power generation. A large amount of the current research and development of new solar technologies is focused on achieving highly efficient systems that could generate electric power at costs that are competitive with fossil fuels and other energy sources (Appleyard, 2009). Roofs have become viable means of mounting solar panels for large power supply. For instance PV roof in Munich airport China covers up to 260,000m<sup>2</sup> and supplies 445MWh electricity (Shimin, 2008). It is also estimated that roofs could technically generate up to 40% of European Union electricity demand (CPR, 2010). With an average daily insolation of 7kwhm<sup>-2</sup> per day (Asiegbu and Nduka, 2006), Umudike has the potential for sustaining large solar power plants. It is hoped that

the successes of this design will serve as a spring board for designing larger and reliable solar plants in the community.

**Theoretical background**

A solar cell is a device that converts solar energy into electrical energy. It operates on the principle of photoelectric effect. The term “solar cell” is used when the device is particularly intended to capture energy from sunlight but the term “ photovoltaic cell” is used when the light source is not specified. An interconnection of solar cells in series to yield higher voltage or in parallel to yield higher current is called a solar module. Interconnection of solar modules is called a solar panel and an interconnection of solar panels is called a solar array. Power output of a solar panel is measured in watts and the power rating of panels are indicated by their manufacturers. Common ratings include 80W, 100W, 140W, 150W, etc.

**The photovoltaic array**

Important parameters for the photovoltaic array are its output voltage, tilting angle and its peak output power. For maximum annual energy production, the solar array should be tilted at same latitude as the location (Asiegba, 2003). A tracking system can also be used (Chung-hua *et al.*, 2009). According to Shimin (2008), the output voltage of a pV array is given by the expression:

$$V_p = (1+0.25)V_b + V_d + V_t \text{ -----(1)}$$

Where,

- V<sub>b</sub> is the voltage of battery group
- V<sub>d</sub> is voltage drop of a blocking diode which is about 0.7V
- V<sub>t</sub> is voltage drop of temperature effect

Also the output power of the pV array according to Shimin (2008) is given by the expression:

$$Q_p (Ph/HN_b N_c N_i) \text{-----(2)}$$

Where,

- P is the total load power of ac or dch is working hours of the loads

- H is the peak sun hours or insolation
- N<sub>b</sub> is charge efficiency of battery
- N<sub>c</sub> is the efficiency of the system Controller

N<sub>i</sub> is the efficiency of the inverter  
However, N<sub>b</sub>, N<sub>c</sub> and N<sub>i</sub> are specified by the manufacturer.

**The solar battery**

Photovoltaic batteries are deep cycle type which charge slowly but efficiently. They provide means of storage as a back up especially at nights or days when the solar radiation is poor. Parameters of interest include battery capacity, charge and discharge rates. Battery capacity, which is the amount of charge stored in the battery, is measured in ampere- hour (AH). It varies with temperature, rate of discharge and age of battery. According to Shimin (2008), battery charge or discharge rate in given by the expression.

$$\text{Rate} = \frac{\text{Total Capacity (AH)}}{\text{Full charge or discharge hours (H)}}$$

$$\text{That is, } R = C/H \text{ ----- (3)}$$

In a given energy system, the group voltage of the battery bank according to Shimin (2008) should be same an the input voltage to the inverter. The capacity of a given battery group in obtained by the expression:

$$Q_b = (PhD/N_b N_c N_i V_b A) \text{ -----(4)}$$

Where,

- D in the number of days of storage
- A is the battery discharge depth.

It is advisable not to allow the battery to discharge completely

**Charge/discharge controler**

Charge/Discharge controllers regulate the amount of current doing in or out of battery when charging or discharging gets to a particular value. There are two types – the single controller and the multistage controller. The single stage controller switches the

array current off when the charging battery reaches the voltage set point. A discharge controller switches off the battery output current when the battery reaches over-discharge voltage set point. A multistage controller reduces the charge current as the battery nears full charge thus providing more efficient charging. The voltage set point is dependent on the battery used in the system and the control current should be greater than system design current.

### The Inverter

An inverter converts dc power to ac power (Asiegbu and Atuke, 2005). Basic types include the synchronous type, used in grid connected systems and the stand-alone type used in stand-alone systems. An inverter may be static or rotary in design. Major consideration for applications include output wave form, power output, efficiency, output regulation and matching to applications. Sine wave form inverters are suitable for all ac loads while square wave form types are not adequate for motor loads.

## MATERIALS AND METHODS

Materials used in this design include: 14 piece of solar panels (150W), 1 piece of inverter 1500 AH/24V, 10 piece of battery 200AH/12V, 1 piece of automatic charge/discharge controller, 14 piece of bypass and block diodes, Array mechanical supports, Switches, Fuses, Wires and connectors, Measuring instruments, etc

The starting point for any design is to first ascertain the average daily radiation per month within the locality. For Umudike community an average daily insolation of about  $7\text{kWhm}^{-2}$  has been recorded (Asiegbu and Nduka, 2006). Secondly the expected load to be driven by the generator was determined at to be

about 3kW. Output power of the required pV array  $Q_p$  was determined to give an idea of the size of panels required according to specifications. Also battery group capacity  $Q_b$  of the system was determined. Design method adopted here is mainly that illustrate by Shimin (2008).

## RESULT

Design objective is to provide power supply that will drive 5 offices by a stand-alone PV system. The load and power budget for each office is given in Table 1. From Table 1,

$$\begin{aligned} \text{Total loads, } P &= 426 \times 5 = 2130\text{W} \text{ -----(5)} \\ \text{Energy consumed} &= Ph = 1620 \times 5 = 8100\text{Wh} \text{ --(6)} \end{aligned}$$

Considering the worst case insolation situation  $5.8\text{kWhm}^{-2}$  for Umudike, the output power of the PV array required is obtained from equation (2) as,

$$\begin{aligned} Q_p &= Ph/HN_b N_c N_i \\ &= 8100/(5.8 \times 0.8 \times 0.98 \times 0.9) \\ &= 1979\text{W} \end{aligned}$$

Similarly, capacity of battery group  $Q_b$  is obtained from equation (4). Since Umudike is in the tropics, we consider storage of 2 days. Also using an arrangement of 24V as battery voltage and discharge dept of 50%, then,

$$\begin{aligned} Q_b &= (8100 \times 2)/(0.8 \times 0.9 \times 4 \times 0.5) \\ &= 1913\text{AH} \end{aligned}$$

Therefore from the values of  $Q_p$  and  $Q_b$  obtained, this design requires 14 panels of 150W each and 10 batteries of 200AH/12V rating.

Table 1. Power Budget for each Office

Load (W)	Quantity	Daily work Hours	Energy consumed (Wh)
126W Refrigerator	1	5	630
80W Electric fan	1	2	160
20W Computer	1	8	160
15W Fluorescent tube	2	2	30
150W Air conditioner	1	4	600
20W Miscellaneous	1	2	40

Total = 1620Wh

## DISCUSSION

Fig. 1 shows the block diagram of the complete design. The array is connected to the charge-discharge controller by means of stopping diodes to

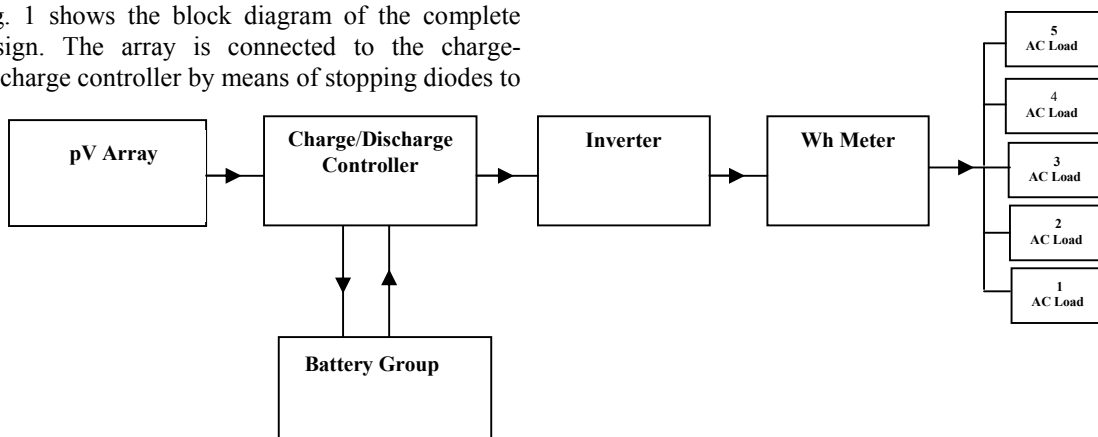

**Fig. 1. Block Diagram of the Designed Solar Energy Plant**

prevent back emf at night. In this design, 14 panels each of 150W have been used, however, 15 panels of 140W or 20 panels of 100W can be used to achieve the same purpose. Also the battery bank is made up of 10 batteries of 200AH/12V rating, this could have been achieved using 14 batteries of 150AH/12V or 20 batteries of 100AH/12V rating. The design can fully sustain the power requirement of 5 offices without any supplementary source. It also has capacity to sustain power from storage for two consecutive days if there was no radiation or poor sun light.

## CONCLUSION

A pV system capable of supplying power that can fully sustain 5 offices has been designed. The design can also sustain power supply from stored energy for a maximum of two consecutive days without sunlight. It is hoped that this design will serve as a launching pad for designing higher power pV system for Umudike Community.

## REFERENCES

Appleyard S. 2009. Assessing the use of simple dye-sensitized solar cells for drinking water chlorination by communities with limited resources. *Science Direct*, 34 (6):165-1654.

Asiegbu A.D and Nduka O.A. 2006. Determination of Solar Insulation in Michael Okpara University of Agriculture Umudike using a photoresistor. *Global Journal of Pure and Applied Sciences*, 2(2):245-250.

Asiegbu, A.D. 2003. Design, Construction and testing of a low-cost flat plate solar Energy Collector. *Global Journal of Pure and Applied Sciences*, 9(1):127-132.

Asiegbu A.D and Atuke A.J. 2005. Design construction and testing of a base-Driven Static Inverter. *Global Journal of Pure and Applied Sciences*, 12 (12): 269-272.

Chung-hua L, Xin-jian Z, Guang-yi C, Wan-qi H, Sheng S and Ming-ruo H. 2009. A maximum power point tracker for photovoltaic energy systems based on fuzzy neural networks, *Journal of Zhejiang University-Science A*, 10(2): 263-270.

Company Press Release, 2010. Roofs could technically generate up to 40% of Eu's electricity demand, European Photovoltaic Industry Association (EPIA) pp. 1.

Shimin L. 2008. Introduction to Photovoltaic Applications Gensu National Energy Research Instituted Asia- Pacific Research and Training Centre for Solar energy. 193p.

\*\*\*\*\*