



ISSN: 0975-833X

Available online at <http://www.journalcra.com>

INTERNATIONAL JOURNAL
OF CURRENT RESEARCH

International Journal of Current Research
Vol. 13, Issue, 11, pp.19720-19723, November, 2021

DOI: <https://doi.org/10.24941/ijcr.42653.11.2021>

RESEARCH ARTICLE

A CHARACTERIZED THYRISTOR CONTROLLED SERIES COMPENSATION FACTS DEVICE FOR PHANTOM POWER CONTROL

*Namburi Nireekshana, Shivani, V., Rohini, A., Prathyusha, B.

EEE Department, Methodist College Engineering & Technology

ARTICLE INFO

Article History:

Received 15th August, 2021
Received in revised form
29th September, 2021
Accepted 18th October, 2021
Published online 30th November, 2021

Keywords

Power Quality,
TCSC,
MATLAB Simulink

*Corresponding author:

Namburi Nireekshana

ABSTRACT

Nonlinear loads connected to electric energy distribution networks generate harmonic pollution. Such nonlinear loads drain currents with varying degree of harmonic contents. The harmonic current components do not represent useful active power due to the frequency mismatch with the grid voltage. A remedy to the harmonic current injection problem is to connect series controllers in transmission lines.

Copyright © 2021. Namburi Nireekshana et al. This is an open access article distributed under the Creative Commons Attribution License, which permits unrestricted use, distribution, and reproduction in any medium, provided the original work is properly cited.

Citation: Namburi Nireekshana, Shivani, V., Rohini, A., Prathyusha, B. "A Characterized Thyristor Controlled Series Compensation FACTS Device for Phantom Power Control", 2021. International Journal of Current Research, 13, (11), 19720-19723.

INTRODUCTION

The quality of power supply is very important in any power network particularly to electricity consumers.

Power quality is poor when at least one of these occurs

- The supply is not constant (outage or interruption),
- When the supplied voltage is lower to or above acceptable range of magnitude,
- When the power system frequency is fluctuating
- And when the current and voltage sinusoidal waveform of the supply.

Power Quality Issues in Power System:

Voltage Sag: Voltage sag or dip represent a voltage fall to 0.1 to 0.9 p.u. and existing for less than one minute. This is shown in fig2 Voltage sag can cause loss of production in automated process since a voltage sag trip a motor or cause its controller to malfunction namely microprocessor based control system,

programmable logic controller, adjustable speed drives, that may lead to a process stoppage, tripping of contractors and loss of efficiency of electric machine. Impact of long duration variation is greater than those of short duration variation.



Figure 2.1. Voltage Sag

Voltage Swell: Voltage swell is the rise in voltage of greater than 1.1 p.u. and exists for less than one minute shown in fig. Swells are usually associated with system fault conditions, but they are much less common than voltage sags. A swell can occur due to a single line-to-ground fault on the system which can result temporary voltage rise on the other unwanted phases. Swells can also be caused by switching off a large load or switching on a large capacitor bank.

Voltage swells can put stress on computer and many home appliances. It also causes tripping of protective circuit of an adjustable speed drive.



Figure 2.2. Voltage Swell

Voltage flicker: Voltage flicker is one of the power quality problem. Due to sudden switching on and off of loads on a weak distribution system voltage flicker occurs. Voltage variations occur due to the small short circuit capacity in the distribution system. It results in rapid variation in voltage due to fast changes in load as shown in fig. The voltage flicker magnitude depends upon type of the electrical load that is producing the disturbance. Voltage flicker can also occur due to the sag in the power system. This voltage sag can generate inrush current and this current passes into the sensitive loads in the distribution system.

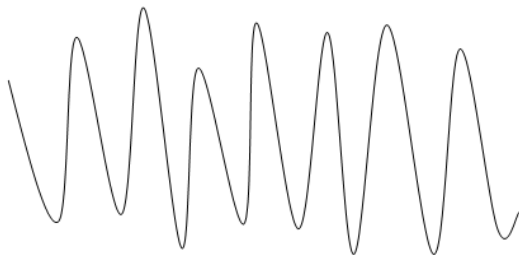

Figure 2.3 Voltage Flicker

High harmonic in distribution system: It is a sinusoidal component of a periodic wave having a frequency that is an integral multiple of the fundamental frequency as shown in fig. Harmonics can be considered as voltages or current present on an electrical system at some multiple of the fundamental frequency. Non-linear elements in power system such as power electronic devices, static power converters, arc discharge devices, and lesser degree rotating machines create current distortion. Harmonics cause wave from distortion power system problems such as communication interference, heating and solidstate device malfunction can be direct result of harmonics.

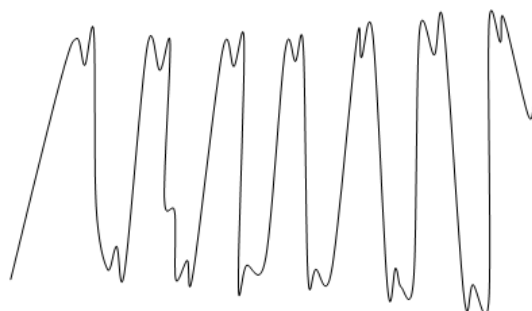

Figure 2.4. Voltage Harmonics

Mitigation of Power Quality Issues: There are two approaches to the mitigation of power quality problems. The solution to the power quality can be done from customer side or from utility side. Solutions for power quality problems:

Lightening and Surge Arresters: Lightening protection of transformers is done by arrestors but can't protect from voltage surges because there is no voltage limit.

Thyristor Based Static Switches: The static switch is a unique device for switching a new element into the circuit when the voltage support is needed. It has a dynamic response time of about one cycle. To correct quickly for voltage sags or interruptions, the static switch can be used to switch one or more of devices such as capacitor, filter, alternate power line, energy storage systems etc.

Isolation Transformers: Isolation transformers consist of two coils:

- Primary and
- secondary.

These are intentionally coupled together, on a magnetic core. Isolation transformers should be designed to minimize the coupling capacitance between primary and secondary sides, while increasing the coupling to ground. Unshielded isolation transformers can only attenuate low frequency common mode noise. High frequency normal mode noise can be attenuated by specially designed and shielded isolation transformers.

Energy Storage Systems: Storage systems can be used to protect sensitive production equipments from shutdowns caused by voltage sags or momentary interruptions. These are usually DC storage systems such as UPS, batteries, superconducting magnet energy storage (SMES), storage capacitors or even fly wheels driving DC generators. The output of these devices can be supplied to the system through an inverter on a momentary basis by a fast acting electronic switch. Enough energy is fed to the system to compensate for the energy that would be lost by the voltage sag or interruption.

Electronic tap changing transformer: A voltage-regulating transformer with an electronic load tap changer can be used with a single line from the utility. It can regulate the voltage drops up to 50%. It can have the provision of coarse or smooth steps.

Working Principle of TCSC: It can be defined as a capacitive reactance compensator. It consists of a series capacitor bank shunted by a thyristor-controlled reactor in order to provide a smoothly variable series capacitance. In a practical TCSC implementation, several such basic compensators may be connected in series to obtain the desired voltage rating and operating characteristics. The idea TCSC scheme is to provide continuously variable capacitor by cancelling the effective compensating capacitance by the TCR. The basic TCSC comprises a series capacitor, C, in parallel with a thyristor controlled reactor. A TCSC can provide continuous control of power on the ac line over a wide range. The principle of variable-series compensation is simply to increase the fundamental-frequency voltage across a fixed capacitor (FC) in a series compensated line by varying the firing angle (α). This voltage changes the effective value of the series capacitive reactance.

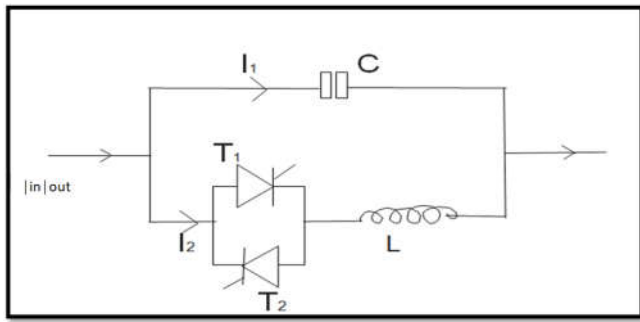

Figure 4.1. Structure of TCSC

Modes of Operation: There are three modes of operation of TCSC depending upon the firing angle of the pulses fed to the thyristor.

- Thyristor blocked mode
- Thyristor bypassed mode
- Vernier operating mode

Thyristor Blocked Operating Mode: When the thyristor valve is not triggered and the TCSC is operating in blocking mode. In this mode, the TCSC performs like a fixed series capacitor.

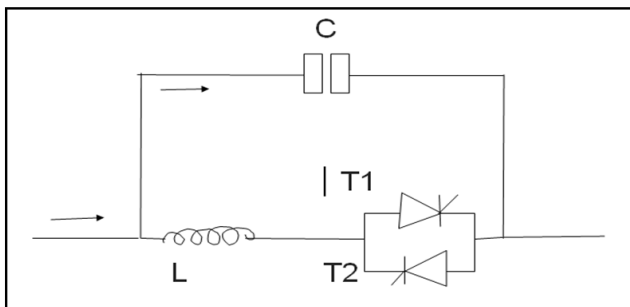

Figure 4.2. TCSC Operation

Thyristor Bypass Operating Mode: In bypass mode the thyristor valve is triggered continuously and the valve stays conducting all the time; so the TCSC behaves like a parallel connection of the series capacitor with the inductor, L_s in the thyristor valve branch. In this mode, the resulting voltage in the steady state across the TCSC is inductive and the valve current is somewhat bigger than the line current due to the current generation in the capacitor bank. For practical TCSC's with ratio (X_L/X_C) between 0.1 to 0.3 ranges, the capacitor voltage at a given line current is much lower in bypass than in blocking mode. Therefore, the bypass mode is utilized as a means to reduce the capacitor stress during faults.

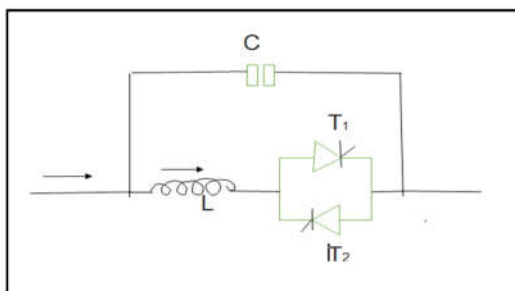

Figure 4.2 TCSC Operation

Vernier Operating Mode: In Vernier control the TCSC dynamics are varied continuously by controlling the firing angle. The firing angle is possible from 0° to 90° for each half cycle when it is generated from the zero crossing of the line current hence divided into two parts:

- Capacitive Boost mode
- Inductive Boost Mode

Capacitive Boost Mode: In capacitive boost mode a trigger pulse is supplied to the thyristor having forward voltage just before the capacitor voltage crosses the zero line, so a capacitor discharge current pulse will circulate through the parallel inductive branch. The discharge current pulse adds to the line current through the capacitor and causes a capacitor voltage that adds to the voltage caused by the line current. The capacitor peak voltage thus will be increased in proportion to the charge that passes through the thyristor branch. The fundamental voltage also increases almost proportionally to the charge.

From the system point of view, this mode inserts capacitors to the line up to nearly three times the fixed capacitor. This is the normal operating mode of TCSC.

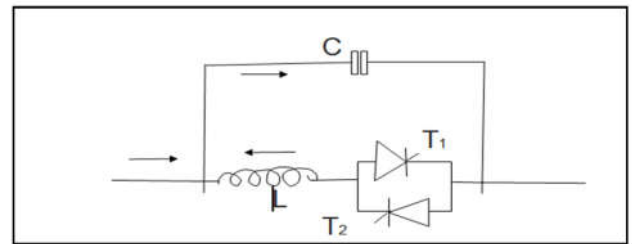

Figure 4.3. TCSC Operation

Inductive Boost Mode: In inductive boost mode the circulating current in the TCSC thyristor branch is bigger than the line current. In this mode, large thyristor currents result and further the capacitor voltage waveform is very much distorted from its sinusoidal shape. The peak voltage appears close to the turn on. The poor waveform and the high valve stress make the inductive boost mode less attractive for steady state operation. There are three modes of operation of TCSC depending upon the firing angle of the pulses fed to the thyristor.

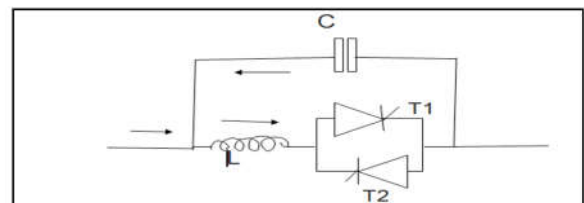

Figure 4.4. TCSC Operation

Advantages

- Rapid, continuous control of the transmission-line series-compensation level.
- Dynamic control of power flow in selected transmission lines within the network to enable optimal power-flow conditions and prevent the loop flow of power.
- Damping of the power swings from local and inter-area oscillations.

- Suppression of subsynchronous oscillations.
- Decreasing dc-offset voltages. The dc-offset voltages, invariably resulting from the insertion of series capacitors, can be made to decay very quickly (within a few cycles) from the firing control of the TCSC thyristors.
- Enhanced level of protection for series capacitors. A fast bypass of the series capacitors can be achieved through thyristor control when large over voltages develop across capacitors following faults. Likewise, the capacitors can be quickly reinserted by thyristor action after fault clearing to aid in system stabilization.
- Voltage support. The TCSC, in conjunction with series capacitors, can generate reactive power that increases with line loading, thereby aiding the regulation of local network voltages and, in addition, the alleviation of any voltage instability.
- Reduction of the short-circuit current. During events of high short-circuit current, the TCSC can switch from the controllable-capacitance to the controllable-inductance mode, thereby restricting the short-circuit currents

Applications

- TCSC device has high potential in applications because it improve power system performance including power flow control, transfer capability enhancement of the transmission system, transient stability enhancement and sub-synchronous resonance (SSR) mitigation etc.
- Accurately regulating the power flow on a transmission line
- Improves transient stability
- Damping inter area power oscillations
- Mitigates subsynchronous resonance
- Post-contingency stability improvement
- Dynamic power flow control

RESULTS AND SIMULATION

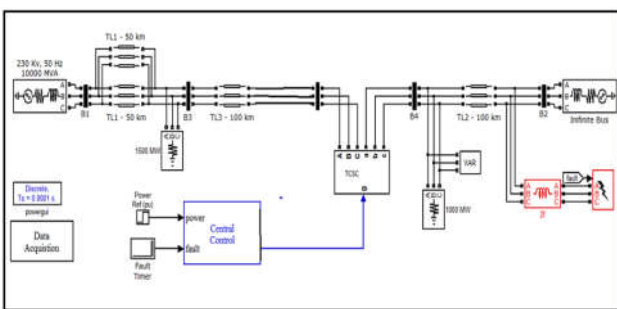

Fig. Representation of simulation circuit

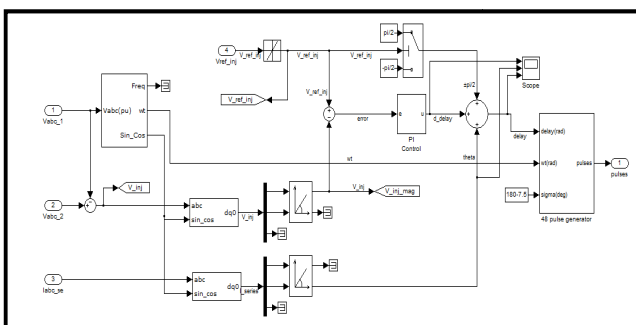

Fig. Representation of control circuit

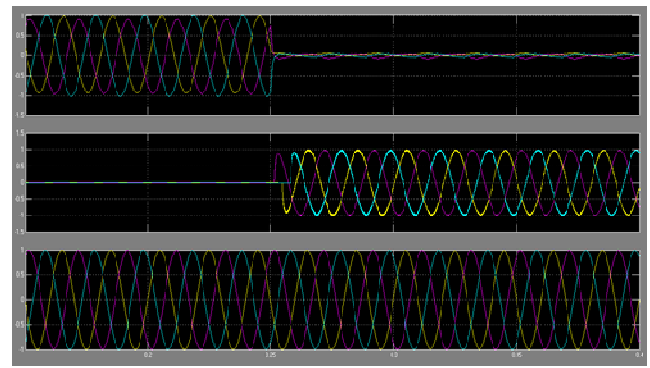

Figure. Output waveforms

CONCLUSION

The proposed configuration could be very useful for modern load centres where strict voltage regulation are required. The proposed configuration can operate in different modes based on the grid condition. The comprehensive simulation study and experimental validation demonstrate the effectiveness of the proposed configuration and its practical feasibility to perform under different operating conditions.

REFERENCES

1. A Peer Survey on Load Frequency Control in Isolated Power System with Novel Topologies Namburi Nireekshana R. Ramachandran International Journal of Engineering and Advanced Technology, ISSN: 2249-8958 (Online).
2. A novel-implementation-fuzzy-pi-based-distributed-power-flow-controller-power-quality improvement and mitigation namburiniireekshana, INTERNATIONAL JOURNAL OF CURRENT RESEARCH, Vol 13 Issue:10
3. Nireekshana, Namburi. "Control of a Bidirectional Converter to Interface Electrochemical double layer capacitors with Renewable Energy Sources."
4. Nireekshana, Namburi. "Reactive Power Compensation in High Power Applications by Bidirectional cascaded H-Bridge Based Statcom."
5. Prasad, CS Pavan, and N. Nireekshan. "A Higher Voltage Multilevel Inverter with Reduced Switches for Industrial Drive." *International Journal of Science, Engineering and Technology Research (IJSETR)* 5.1 (2016).
6. Rajinikanth, BhumaiahJula, and N. Nireekshan. "Improving the Voltage Profile at Load End using DVR." (2018).
7. Jatoth, Ramesh, and N. Nireekshana. "Improvement of Power Quality in Grid Connected Non Conventional Energy Sources at Distribution Loads." (2018).