



ISSN: 0975-833X

Available online at <http://www.journalcra.com>

International Journal of Current Research  
Vol. 14, Issue, 10, pp.22552-22555, October, 2022  
DOI: <https://doi.org/10.24941/ijcr.44188.10.2022>

INTERNATIONAL JOURNAL  
OF CURRENT RESEARCH

## RESEARCH ARTICLE

# DESIGN OF AUTOMATIC STAR-DELTA STARTER BY ADJUSTABLE ELECTRONIC TIMER AND RELAYS FOR INDUCTION MOTOR

<sup>1,\*</sup>Godwin Effiong, <sup>2</sup>Efiyeseim Okumo Sample Ikeremo and <sup>3</sup>Ayibapreye Kelvin Benjamin

<sup>1</sup>Department of Physics, University of Calabar

<sup>2,3</sup>Department of Electrical, Electronic Engineering, Niger Delta University

### ARTICLE INFO

#### Article History:

Received 20<sup>th</sup> July, 2022  
Received in revised form  
17<sup>th</sup> August, 2022  
Accepted 19<sup>th</sup> September, 2022  
Published online 30<sup>th</sup> October, 2022

#### Key words:

Automatic, Star-Delta Starter, Adjustable Electronic Timer, Relays, Induction Motor.

\*Corresponding Author:  
Godwin Effiong

Copyright©2022, Godwin Effiong et al. This is an open access article distributed under the Creative Commons Attribution License, which permits unrestricted use, distribution, and reproduction in any medium, provided the original work is properly cited.

Citation: Godwin Effiong, Efiyeseim Okumo Sample Ikeremo and Ayibapreye Kelvin Benjamin. 2022. "Design of Automatic Star-Delta Starter by Adjustable Electronic Timer and Relays for Induction Motor". *International Journal of Current Research*, 14, (10), 22552-22555.

### ABSTRACT

This paper reports the design an automatic star-delta starter using electrical relays and an electronic timer by feeding the motor with  $\frac{1}{\sqrt{3}}$  (58%) of the full load current to limit the starting current surges by starting the motor at reduced voltage and then have full supply voltage reconnected when they run up to near rotated speed. This method is commonly referred to as "Soft Starting" the motor. Traditionally, in many regions there is a requirement that all motor connections be fitted with a reduced voltage starter for motors greater than 4 KW5HP. This is necessary to curb the high inrush of starting currents associated with starting induction motors. In this paper, a low cost-based circuit that can be used to control the operation of an induction motor is designed and a delta-star starter is used in controlling the turning on of the motor with low power loss and electrical relays deployed for conversion of star to delta. This design reduces the high starting current of induction motor and along these lines forestall the motor from overheating.

## INTRODUCTION

The induction motors have a wide characteristic and its application is required in industries. The characteristics of the induction motor ranges from self-starting, rugged construction, high efficiency, good power factor and ease of control, etc. The induction motor at an idle state looks like a short-circuited transformer at secondary side because all its rotor bars are connected together to form a closed path. However, when the motor is started, the stator draws the high current which is 8-10 times that of the motor rated current and coils get heated up, damaging the motor. Hence there is a need to control the motor starting. One way is to reduce the applied voltage, which in turn reduces the torque. Most of the machines used in the industries are three phase induction motors. They have simple and rugged construction and their robust nature make them possible to operate in all environmental condition. Also, induction machines are cheaper in cost and maintenance free. They have starting torque and are widely used in domestic and industrial applications. During starting of an induction motor, the starting current is around eight to ten times the rated current and this persists for a few cycles. This may be very much detrimental for the machine, causing a disturbance of voltage on the supply lines due to large starting current surges (Suvra Gupta, 2012). To limit the starting current surges, large induction motors are started at reduced voltage and hen have full supply voltage reconnected when they run up to near rotated speed.

These forms of starters are known as reduced mechanical starters, they are used to replace the direct-on-line starters. This is because of their controlled starting capability with lower starting current during the soft start period. According to Suvra Gupta 2012-2014, direct-on-line is the simplest form of motor starter for induction motors. It consists of a MCCB or circuit breaker, contactor and an overload relay for protection. It can be used if the high inrush current of the motor does not cause excessive voltage drop on the supply current (Suvra Gupta, 2012). Voltage reduction during star-delta starting is achieved by physically reconfiguring the motor winding. During starting, the motor windings are connected in star configuration and this reduces the voltage across each winding. This also reduces the voltage by a factor of three. After a period of time the winding are reconfigured as delta and the motor runs normally. The star-delta starter is generally obtained from three contactors; electromechanical timer and a thermal overload relay for operating a 3-phase motor at 440 volts at ac mains supply of 50Hz. The current through the windings are  $\frac{1}{\sqrt{3}}$  (58%) of the current in the line. The star-delta starter is simple and rugged, relatively cheap compared to other reduced voltage methods with good torque and current performance. The widely application of the three-phase induction motor in industries is a subject of interest and requires every possible perspective. It has a number of significant advantages compared to their single and even DC counterparts. Some of these advantages include: high level versatility, minimum attention requirement,

ruggedness, durability, ability to start from rest with no extra starting motor or external initial force required and they require reasonably simple starting arrangement without need for synchronization unlike synchronous types. Nevertheless, they experience a couple of limitations such as speed variation at expense of efficiency, speed decrease as load increases and an inferior torque to a DC shunt motor etc. Alternating current technology was rooted in Michael Faraday's and Joseph Henry's 1830-31 discovery that a changing magnetic field can induce an electric current in a circuit. Faraday is usually given credit for this discovery since he published his findings first (Thompson, 2017). In 1888, Ferraris published his research to the Royal Academy of Sciences in Turin, where he detailed the foundations of motor operation; Tesla, in the same year, was granted a United States patent for his own motor. Working from Ferraris' experiments, Mikhail Dolivo-Dobrovolsky introduced the first three-phase induction motor in 1890, a much more capable design that became the prototype used in Europe and the U.S (Ferraris, 1888).

He also invented the first three-phase generator and transformer and combined them into the first complete AC three-phase system in 1891. The three-phase motor design was also worked on by the Swiss engineer Charles Eugene Lancelot Brown, and other three-phase AC systems were developed by German technician Friedrich August Haselwander and Swedish engineer Jonas Wenström (Babbage, 2017). However, some techniques different modalities have been put in place to provide overload no voltage protection to aid safe starting of three phase induction motor by avoiding the high initial inrush currents from overheating the windings leading to burning out of the windings and hence damaging the motor. These techniques include: Direct On-Line (DOL) Starter, Primary (stator) resistance starter, Autotransformer starters and Star-Delta starters. Each starter arrangement has associated with it a number of advantages and disadvantages and most importantly the complexity (a figure of interest) of each circuit varies from one method to the other (Review and general assessment of star-delta starter). This chapter intends to briefly examine some of the starter circuits mentioned and dwelling more on the star-delta starter in an in-depth treatment. Terrel and Wiltord Summers asserted that direct-on-line starter may be limited by the supply utility requiring rural customers to use reduced voltage starters for motors not larger than 10 KW (Terrel Croft, 1987). The motor used with direct-on-line will reach its full speed provided the torque developed by the motor exceeds the load torque at all speeds during the start cycle. Also, the motor will cease accelerating if the torque delivered by the motor is less than the torque of the load at any speed during the start cycle. According to J. Nevelsteen and H. Aragon, direct-on-line starting may create problems when the ac supply is weak because it may cause low voltage at the starting which is a constraint as during starting too much reduction in voltage is detrimental (Nevelsteen, 1989).

## METHODOLOGY

### Hardware Components:

- Transformer (230 – 12 V AC)
- Voltage Regulator (LM 7805)
- Rectifier
- Filter
- Relay
- Induction Motor
- 555 Timer
- BC 547 Transistor
- BC 558
- IN4007 Rectifier Diode
- LED
- Resistor
- Capacitor

### Design Analysis

- The control of an automatic Star-Delta Using Relays and Adjustable Electronic Timer for Induction Motor is made up of the following stages;

- Power Supply
- The three phases of an AC source
- Transformers
- Input stage: the input stage comprises
- The star and delta configuration relays
- Control stage
- Electronic adjustable timers
- Output stage
- Motor system

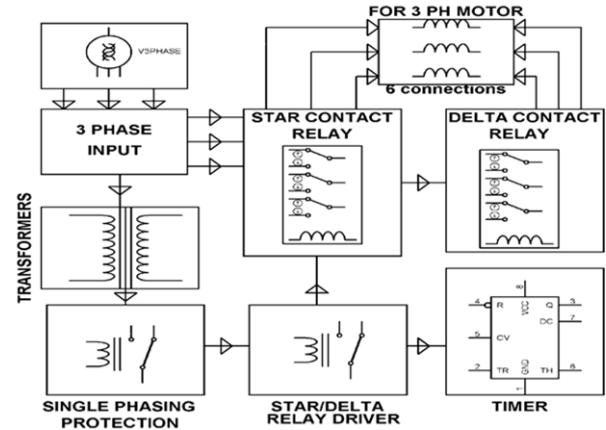

Figure 1. Block Diagram of Automatic Star-Delta Starter with Adjustable Electronic Timer and Relays

**The Power Supply Unit:** This makes use of three phase system connected to the motor and the transformers. The 3 step-down transformers, the primary of which are connected in star mode while their secondary develop filtered dc after passing through respective bridge rectifiers and filtered capacitors. The main contactor connects the reference source voltage R, Y, B to the primary terminal of the motor U1, V1, W1. In operation, the main contactor and the star contactor are closed initially, and then after a period of time, the star contactor is opened, and the delta contactor is closed.

**The Input Unit:** These relays are the star connected relays which is used to switch on the motor, using low voltage. This voltage is reduced by a factor of root three. Two of the rectified dc voltages are connected to the relay to serve as input to it. The R, Y, B are the three phase line voltages which are given to the primary electrical relay. The main motor coils are U, V and W in the star mode of the motor windings, the primary electrical relay connects the mains to the U1, V1, and W1. The star connected relay shorts the U2, V2 and W2.

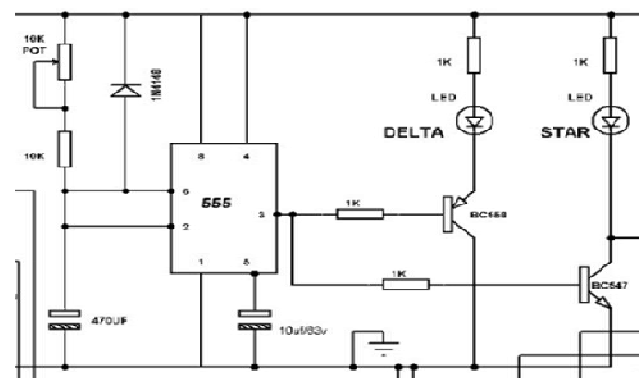
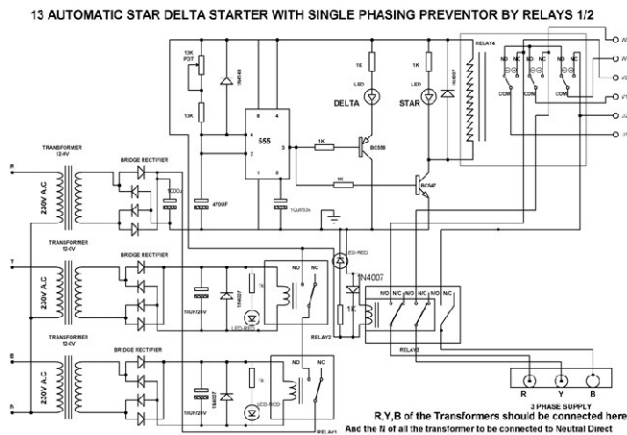

Figure 2. Control Circuit Diagram Of The Automatic Star/Delta Starter

**Control Unit:** The control unit is the adjustable electronic timer which is used to switch operation from Star to Delta connections. The electronic timer is the 555 timer connected in the monostable configuration. The timing or delay is achieved from the RC oscillator connected to the 555 timer. The RC oscillator comprised of resistor 1k, 10k pot and the 470uF capacitor.

When the circuit is turned on, the timer allows the star connected relay to turn on. The output of the 555 timer (pin 3) is connected to the NPN transistor (BC547), this is used to switch on the output relays connected in Star configuration for a particular timing. After the time delay elapsed, the BC547 transistor will switch off and the PNP transistor (BC558) will switch on. The conversion from Star to Delta enables the motor running on the Star mode with a decreased voltage and current to produce less torque to the Delta mode. Thus, enabling the motor run on its full power, utilizing high voltage and current to transform a high torque.

**Output Unit:** Proper supply together with the efficient working and control of the input and control unit helps the induction motor from overheating.



**Figure 3. Circuit Diagram of Automatic Star-Delta Starter Using Relays and Adjustable Timer**

**Manual for Operation:** Star – delta starter generally comprises of contactors and an adjustable timer to enable starting of the induction motor in star mode and switchover to delta mode after the preset time prompted by the 555 Timer. Here, we report the use of 3 step-down transformers, the primary transformers are connected in star mode while the secondary develop filtered dc after passing through respective bridge rectifiers & filter capacitors out of the three such dc derived, one dc is used for a timer circuit built around a 555 Timer wired in astable mode but operating in monostable mode. Two other dc supplies operate relay – 1 and relay – 2 the contacts of which are connected in series with relay -3 coil, to the first dc supply. Relay – 3 switches ON only if relay 1 & 2 are ON meaning supply at R, Y and B are available. The output contacts of relay – 3 are fed to relay – 4 Q<sub>1</sub>, NC contacts both of which are 3 – CO relays. Thus, the R, Y, B fed to relay – 3 each NO contacts of relay – 4.

All the NO contacts of relay – 4 are joined together to develop a star-mode configuration to the motor connection coil U<sub>1</sub>-U<sub>2</sub>, V<sub>1</sub>-V<sub>2</sub>, W<sub>1</sub>-W<sub>2</sub>. While relay 4 is switched ON by the timer IC; after main supply switch ON taking a time delay, the contacts of relay 4 bring the motor connections to delta mode by the NC contacts duly wired. Single phasing means any one or two phases Y & B missing will trigger either relay – 1 or relay - 2 to off condition that results in relay – 3 to switch Off. Also, when phase R is not available the relay -3 is also switched off since the coil gets supply from this phase. Thus, relay – 3 switch off and prevents the input 3-phase to reach the motor supply to protect the same for single phasing. At the time of switch ON, monostable 555 Timer delivers high at PIN3 that switches ON BC547 to switch ON the relay – 4 that enables star mode operation. The star LED connected across the relay – 4 coil indicates that the motor is running in star mode. After the time over by the RC time constant formed out of 470k potentiometer in series with 68k resistor and the capacitor of 470µF, and connected to PIN 2 and 6 of the 555 Timer, it helps to form monostable like operation. PIN3 goes low to switch ON BC558, a PNP transistor that switch ON an LED named as delta to indicate the motor running in delta operation and the relay 4 is switched off enabling the motor to run in delta mode.

## RESULTS AND DISCUSSION

**Testing:** Testing is one of the most important stages in the development of any new product or repair of existing ones due to the fact that it is difficult to trace a fault in a finished work, especially when the work to be tested is too complex. Hence the test carried out in this work are discussed below.

**Continuity Test:** The continuity test was performed by placing a small voltage (wired in series with a LED or noise-producing component such as a piezoelectric speaker) across the chosen path. If electron flow is inhibited by broken conductors, damaged components, or excessive resistance, the circuit is "open". The devices that was used to perform this test include multi meters which measure current and specialized continuity testers which are cheaper, more basic devices, generally with a simple light bulb that lights up when current flows. This test was performed just after the hardware soldering and configuration has been completed. This test aims at finding any electrical open paths in the circuit after the soldering. Many a times, the electrical continuity in the circuit is lost due to improper soldering, wrong and rough handling of the PCB, improper usage of the soldering iron, component failures and presence of bugs in the circuit diagram. A multimeter was used to perform this test. It was kept in a buzzer mode and then connected to the ground terminal of the multimeter to the ground, both terminals across the path that needs to be checked was connected together. If there is continuation then you will hear the beep sound.

**Power on Test:** This test was performed to check whether the voltage at different terminals meets design requirement or not. The multimeter was kept in voltage mode and the test performed without ICs. Firstly, the transformer was checked if the required 12V AC output voltage was obtained (depending on the transformer used in for the circuit). If a battery were to be used, it will be checked if it is fully charged or not according to the specified voltage of the battery by using a multimeter. The voltage gotten was applied to the power supply circuit. This test was done without ICs because if there is any excessive voltage, this may lead to damaging the ICs. If a circuit consists of voltage regulator, then the input to the voltage regulator will be checked for all ICs. For instance, if the required input is 12V and the output voltage will be obtained depending on the regulator used in the circuit. IC 7805 will bring an output of 5V while IC 7809 will produce 9V at output PIN and so on. The output from the voltage regulator is given to the power supply PIN of specific ICs. Hence, the voltage level at those PINS were checked if the required voltage was obtained. Similarly, checks for the required voltages on other terminals was carried out. Lastly, we were able to verify that the voltages at all the terminals met the design requirement.

## CONCLUSION

The starting current of an induction motor is around eight to ten times the motor rated current. The high current persists for a few cycles. Since the windings of the motor are designed to carry maximum of rated current, this high current during starting can be hazardous. This approach was able to limit the starting current of the induction motor with the use of reduced voltage electromechanical starter. Automatic Star/Delta starter using relays and adjustable electronic timer is used and the starting current and torque is limited to one-third as compared to nine times in open loop. It provides only 33% starting torque and if the load connected to the subject motor requires higher starting torque at the time of starting than very heavy transients and stresses are produced while changing from star to delta connections, and because of these transients and stresses many electrical and mechanical breakdown occurs. In this method, the motor is initially connected in star and after change over the motor is connected in delta. When starting up pumps and fans for example, the load torque is low at the beginning of the start and increases with the square of the speed. When reaching approx. 80-85 % of the motor rated speed the load torque is equal to the motor torque and the acceleration ceases.

To reach the rated speed, a switch over to delta position is necessary, and this will very often result in high transmission and current peaks. In some cases, the current peak can reach a value that is even bigger than for a D.O.L start. Applications with a load torque higher than 50 % of the motor rated torque will not be able to start using the start-delta starter.

## REFERENCES

- Suvra Gupta, "Fuzzy Logic Based Soft Starting of Induction Motor With Current Control", National Institute of Technology, Rourkela, (2012-2014).
- Thompson, Silvanus Philips, "Polyphase Electric Currents and Alternate-Current Motors", (1<sup>st</sup> ed.). London: E. & F.N. Spon. P. 261, 1895. Retrieved 1<sup>st</sup> March, 2017.
- Ferraris, G. Attidella Reale Academia delle Science di Torino". XXIII: 360-375. 1888.
- Babbage, C; Herschel, J.F.W. Account of the Repitition of M. Arago's Experiments on the Magnetism Manifested by Various substances during the Act of Rotation. Philosophical Transactions of the Royal Society, 1825. Retrieved 1<sup>st</sup> March,2017.
- Review and general assessment of star-delta starter, <https://www.coursehero.com/file/120658/final-chapter-two/literature> .
- Terrel Croft and Wiltord Summers (ed), American Electricians Handbook, Eleventh Edition, McGraw Hill, NEW York (1987) ISBN 0-07-013932-6 pgs 78-150 through 7-159.
- Nevelsteen J. and Aragon, H. 1989. "Starting of large motors-vol.25,pp.1012-1018/Nov.

\*\*\*\*\*